

A Novel Approach for Video Transmission in MANET

Sonal Mishra^{#1}, Anil Singh^{*2}

[#]Department of Computer Science, Medi-Caps Institute of Technology and Management
Indore, M.P, India

Abstract— MANETs are becoming more essential to wireless communication because of increasing popularity of mobile devices. However, MANETs does not seem to effectively support live video transmission and multimedia applications. The main objective of this work is to improve the performance of real-time video transmission using cross layer technique. The main obstacle in real-time video transmission is delay-jitter. The proposed strategy minimizes delay-jitter problem using the cross layer approach from the integration of MAC, network and transport layer. At the MAC layer, traffic classifier is used to classify various application data using IEEE 802.11e. Various application data i.e. video, voice, text etc are classified and a separate queue of specific data is formed for each application. . At the network layer, SNR information is used that is provided by the MAC layer. A predefined threshold is used at the network layer. If the received SNR is less than a predefined threshold, then the new route discovery process is initiated. At the application layer Application Packet Rate Controller (APRC) function is used. The APRC feedback packet is received from the receiver end and on the basis of information in the feedback packet flow control is adjusted at the application layer. This process minimizes congestion in the channel and hence delay jitter is reduced. We also provided SNR information from the MAC layer in the APRC feedback packet. The advantage is that if the channel is congested due to poor range between sender and receiver, then also the flow control is adjusted accordingly.

Keywords— MANET, IEEE 802.11e, SNR, cross layer, delay-jitter.

I. INTRODUCTION

Mobile ad hoc networks consist of wireless hosts that communicate with each other in the absence of a fixed infrastructure. Routes between two hosts in the network may consist of hops through other hosts in the network. Each node acts as a host and a router at the same time. This means that each node participating in a MANET commits itself to forward data packets from a neighbouring node to another node until the packet reaches its final destination [1]. Mobile ad-hoc networks have many characteristics which distinguish them from other wireless networks. These factors are: no fixed network infrastructure, dynamic network configuration, node mobility and frequent node failure, low battery power, etc. which makes routing in MANETs quite a challenging task [2]. MANET has many emerging applications, which include commercial and industrial, war front applications, search and rescue operations, sensor networks and vehicular communications. Video streaming in MANETs is one of the most challenging issues.

Video streaming is multimedia that is constantly received by and presented to an end-user while being delivered by a provider. Video streaming requires a camera to capture video, an encoder to encode video, a media publisher and a network to deliver and distribute video. There are various techniques for video streaming in MANET.

- Multiple Description Coding (MDC).
- Multipath routing.
- Cross layer technique.

Main obstacle in video streaming is delay jitter. Variation in delay is known as delay jitter. Fig 1 illustrates delay jitter mechanism. Initially packets are evenly spaced apart, but due to network congestion or improper queuing this delay is not constant and vary with time. For ex - delay between packets 1 and 2 is not same as delay between packets 3 and 4.

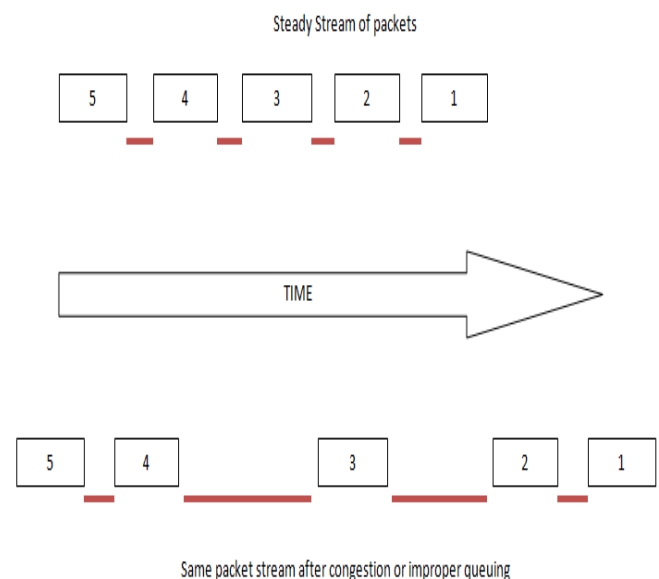

Figure 1 Delay Jitter

Delay jitter occurs in MANET because of following reasons:

- Delay Jitter at MAC layer due to interface queue.
- Delay jitter due to frequent route breaks.
- Delay Jitter due to congestion in the network.

Congestion in the network occurs because of following reasons:

- Congestion due to less receiving power of receiver node.

- Congestion due to poor range between two nodes.

In our research work, we use cross layer technique to minimize delay-jitter in video transmission in MANET.

The rest of the paper is organized as follows. Section 2 reviews related work in video transmission in MANET.. Section 3 describes proposed work. Section 4 describes simulation work carried out and result analysis. Section 5 finally describes conclusion.

II. RELATED WORK

V. K. Goyal [9] proposed Multiple Description Coding (MDC) scheme for video transmission. MDC encodes the source stream into multiple sub-bit streams. The sub streams are also known as descriptions. Each sub stream has equal importance because it carries some unique information. Sub streams are transmitted over multiple independent channels in a network. Because the loss of one sub-stream does not influence other sub-streams, a lost packet in any path does not need to be retransmitted. J. G. Apostolopoulos [10] proposed a scheme that is the combination of two sub-systems. Multiple state video encoding and decoding and path diversity transmission system. Initially, a video stream is encoded into various independently decodable streams. Different network path is chosen for transmitting each stream. The advantage of this method is that if a stream is lost, then it can be recovered with the help of other received streams. The path diversity transmission system is used to send different packets over multiple paths. Since various streams are transmitted over different paths, there are fewer chances that all the streams are simultaneously corrupted. S. Mao et al [11] proposed three MCP-based video transmission techniques for MANET. The techniques are (1) Feedback Based Selection method (2) Layered Coding technique (3) Motion compensation coding using multiple description. In feedback based selection, the reference frames are selected based on feedback and predicted path status. Reference frame is the last frame which is correctly received. Layered coding with selective ARQ makes the use of layered video coding in which video is encoded into two layers EL and BL. The video quality is further enhanced by applying multiple description motion compensation coding technique. M. Tesanovic et al [12] proposed a new scheme for enhancing the quality of video transmission in MANET. This scheme uses two techniques MIMO and MDC. Space time block coding [13] and spatial multiplexing is used as MIMO techniques. Firstly, we apply the MIMO technique on the video data and then the video quality is again refined by applying MDC technique. J. Kim et al [14] proposed channel adaptive MDC technique for reliable video transmission in wireless networks. This system uses an optimized splitting algorithm. In this technique, MDC produces two correlated sub-streams from a single description coder using an optimized splitting algorithm. This system is robust and provides a relatively good value video at the receiver end. P. Timothy et al [15] proposed a method to deliver H.264/SVC video stream over MANET using a multipath routing protocol MP-OLSR

(Multipath Optimized Link State Routing) with Unequal Error Protection (UEP) scheme. The SVCEval is built as an evaluation framework for H.264/SVC video network transmission.

The technique of using multiple alternative paths in a network is known as multipath routing. Multipath routing can improve QoS by providing fault tolerance and load balancing. As there are multiple paths available, so if route is not available, then data can be transmitted on the other available routes. Load balancing is achieved by transmitting data packets on different network path. So there is a less probability that all the paths are simultaneously congested. M. A. Igartua et al [16] proposed a multipath routing technique. In this technique, initially routes are discovered by using dynamic source routing and a probe message packet is transmitted from source to destination using these routes. Once the first probe message is received at the destination end, a time out is triggered. The probe message reply packet is sent to the source using the same path from which it is received. Routes are classified as best route, medium route and worst route. Various paths are used for sending data according to data priorities. Best path is used for sending high priority packets, medium path is used for transmitting medium priority packets and worst path is used for sending least priority packets. Dalei Wu et al. [17] proposed an application-centric routing framework for real-time video transmission in multihop wireless networks. They designed application-centric cross layer strategy to solve multi-hop routing problem. This approach minimizes end-to-end delay at the receiving end by computing an optimized routing path. Within the proposed quality-driven framework, video source coding has been integrated into the path routing to enhance the feasibility of multi-hop routing. N. Gomathi et al [18] proposed a new method for improving the quality of multimedia applications in mobile adhoc networks. This method uses UDPlite protocol for the fast delivery of video data.

V.C. Frias et al [19] proposed Vista-XL. QoS-provisioning for applications over the mobile adhoc network is achieved by using cross layer design. Main module of Vista-XL is XLO, which periodically gathers information from all layers and allows real-time optimization across the protocol stack. P. A. Chaparro et al [20] proposed a new scheme based on Distributed Admission Control for MANET's – Scalable Video DACMSV. It computes end-to-end delay and available bandwidth using periodic probing process. DACME-SV uses a cross-layer approach to determine the optimum number of video layers to transmit at any given time.

III. PROPOSED WORK

Performing real-time video transmission over MANET introduces problems because of strict bandwidth and delay requirements. Live video transmission requires much less delay jitter as compared to other applications. Now we solve the problem of delay jitter by using cross layer technique.

A. Delay Jitter at Mac Layer Due to Interface Queue

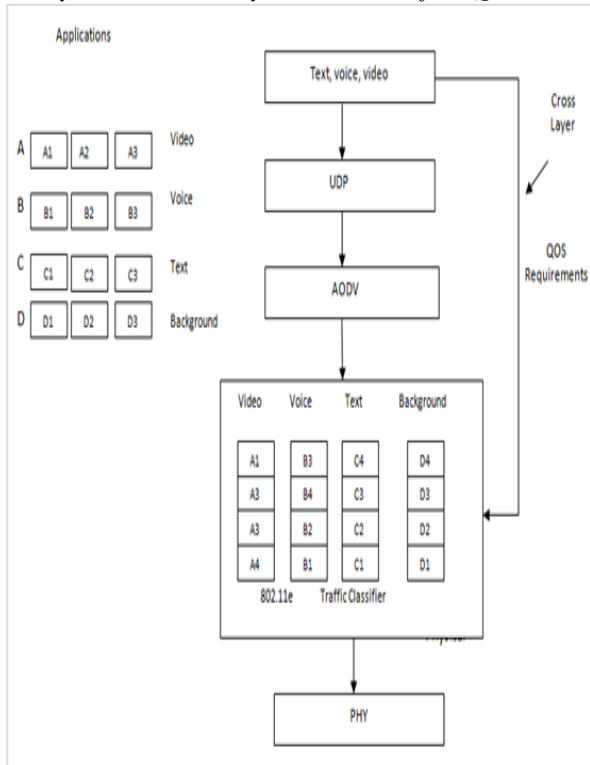

Fig 2 Cross Layer between Application Layer and MAC Layer

TABLE 1 IEEE 802.11e PARAMETERS

	TC [0] Video	TC [1] Voice	TC [2] Text	TC [3] Background applications
PF	2	2	2	2
AIFS	2	2	3	7
CW_MIN	7	15	31	31
CW_MAX	15	31	1023	1023
TXOP limit	0.002	0.006	0	0

Table 1 shows QoS parameters for various traffic categories. We consider four TCs for our proposed work. These parameters are taken from IEEE standard for information technology 802.11e [6]. Parameters for each traffic class are described below:

- 1) *Transmission Opportunity (TXOP)*: A station can transmit frames only during the time interval defined by the EDCF transmission opportunity limit.
- 2) *Arbitration Interframe Space (AIFS)*: When a station wants to transmit data, it first checks that the medium is idle for a duration defined by the arbitration interframe space (AIFS [TC]). If the medium is idle for AIFS [TC] then it performs a random backup procedure. AIFS is different for different traffic categories. The equation used to calculate AIFS is as follows:

$$AIFS = SIFS + n * Slot\ time$$

- 3) *Contention Window (CW)*: Contention window is used to select the value of random backoff counter. Each station has a contention window. Backoff counter is an integer and its value is chosen randomly out of an interval between 0 and CW.
- 4) *Persistence Factor (PC)*: After any unsuccessful transmission, contention window is increased to avoid further collision. Maximum value of contention window is CW_MAX. Persistence factor is different for each traffic class.

B. Delay Jitter due to Frequent Route Breaks:

MANET is a limited resource based network. Transmission range of a node is one of the major limitations of the MANET. Due to mobility, when two nodes move in the opposite direction to each other, then the transmission range between the nodes reduces their strength due to noise and distance.

The measure of signal strength is S/N ratio:

$S/N = x \geq t$ in high end, the signal is strong.
 $S/N = y < t$ in low end, the signal is weak.
 Where t is the threshold value of the link.

Due to mobility in MANET, a frequent route break occurs during transmission of data. The routing protocol AODV uses route maintenance process when the route break occurs. During route maintenance process data transmission is stopped. Due to this pause in data transmission, delay jitter occurs in video transmission.

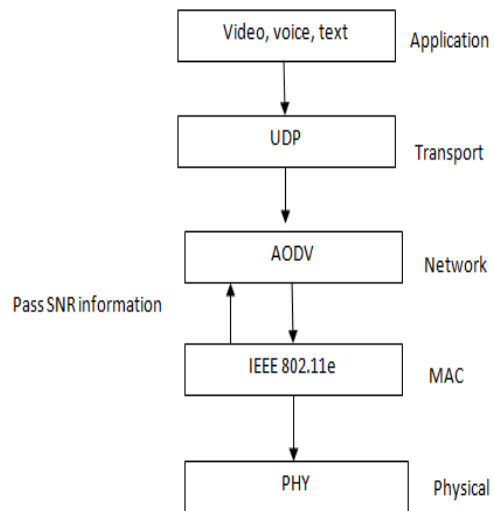

Figure 3 SNR Information Provided to the Network Layer from the MAC Layer

Figure 3 shows proposed feedback technique for a stable route in MANET. In this technique MAC layer, calculate the S/N ratio of the link and forward it to network layer. Network layer checks received S/N with the threshold. If

the received S/N is less than the threshold, then AODV initiates route maintenance and create a new route.

Due to advance route maintenance, the data transmission is not interrupted and the delay jitter between packets is reduced.

C. Delay Jitter due to Congestion in the Network:

Delay jitter due to congestion occurs because of following reasons:

- 1) *Congestion Due to Less Receiving Power of Receiver Node:* Flow control is an important part of the network communication system. When the transmission rate of sending node is higher than the capacity of the receiving node, the link faces the congestion problem. Due to this congestion at the link, the delay between the packets is not synchronized and packets suffer delay jitter in between them.

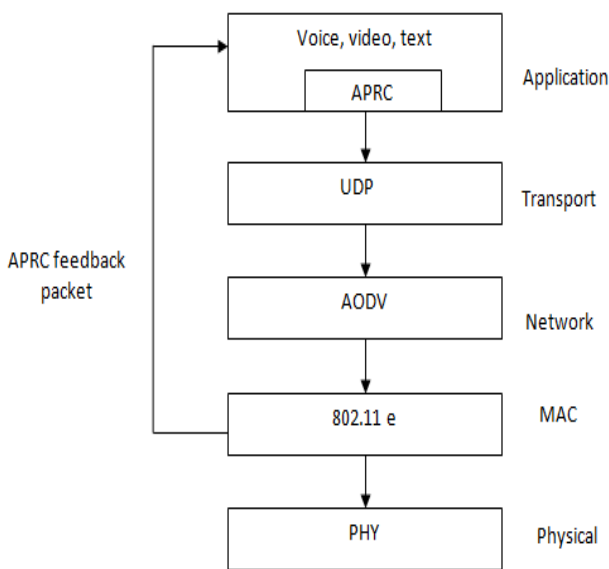

Figure 4 Feedback Message from MAC Layer to Application Layer

Figure 4 shows proposed cross layer approach between MAC layer and the application layer. MAC layer receives APRC (Application Packet Rate Controller) packet from receiver end and forward it to the application layer. Application rate controller at the application layer receives the packet, and controls the rate of data transmission as per receiver’s requirement. This maintains synchronization between sender and receiver and link will not face the problem of congestion.

- 2) *Less Transmission Power of Link between Sender and Receiver:* Due to mobility when the two nodes move in the opposite direction, the link between the nodes will lose its strength because of noise.

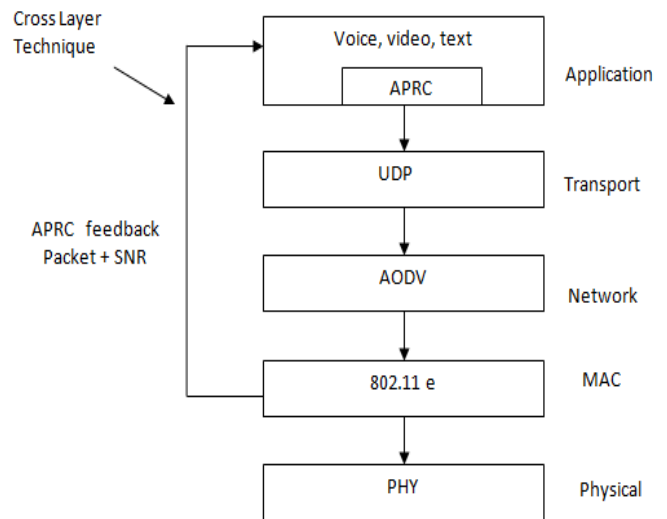

Figure 5 Cross Layer between MAC Layer and Application Layer.

Due to noise, the bandwidth of the link is reduced and hence the transmission rate is also reduced. This leads to congestion in the link and delay jitter problem occurs.

Figure 5 shows proposed cross layer architecture in which MAC layer forwards “SNR” ratio to the application layer and the application rate controller adjusts the rate of the transmission according to link strength. This reduces congestion in the link and delay jitter between the packets minimizes

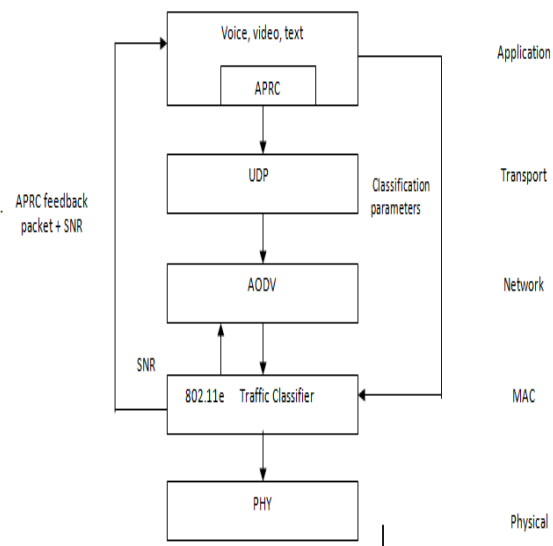

Figure 6 Integrated Cross Layer Architecture

Figure 6 shows proposed integrated cross layer architecture for MANET. This architecture provides real time video transmission with stable route, traffic classification and rate controller of transmission.

IV. SIMULATION AND RESULT ANALYSIS

NS 2.35 is used to simulate the proposed algorithm. We use a raw video which consists of 200 frames and has a duration of 50 seconds. The MPEG-4 video file is produced by encoding this raw video.

Table 2 SIMULATION PARAMETERS

No. of nodes	100
Simulation duration	100 seconds
Simulation Area	500 x 500 m
Protocol	AODV
Data rate	2 Mbps
MAC	802.11e
Mobility model	Random Way Point

We simulated 100 mobile nodes in a 500 meter x 500 meter region for 100 seconds. The simulated traffic is constant bit rate (CBR). The network protocol used is AODV. Table 6.1 shows the simulation parameters.

The performance of the proposed design is evaluated in following scenarios.

- Firstly, we perform the video transmission using base technique i.e. normal TCP/IP model.
- Secondly, we use traffic classification in order to prioritize the video data against other applications.
- The last scenario uses both cross layer technique and traffic classification for further performance improvement.

We examine routing overhead, end-to-end delay and packet delivery ratio for result analysis.

A. Routing Overhead

Routing overhead is defined as the total number of control packets transmitted in the network. It is measured in packets.

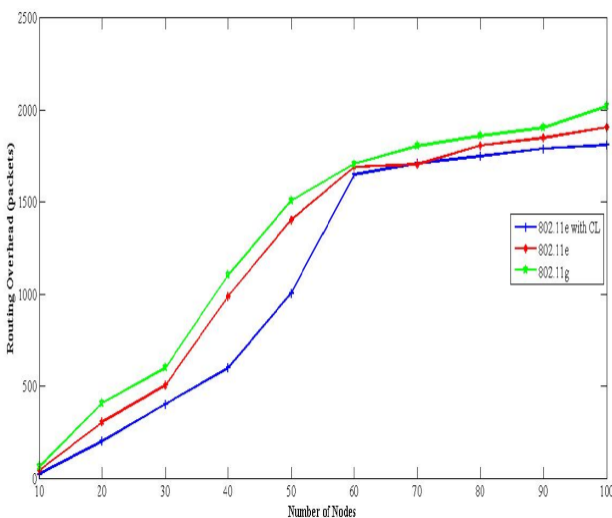

Figure 7 Routing Overhead

Figure 7 shows routing overhead in packets. When the network load increases, the routing overhead also increases, but as compared to base technology, cross layer architecture performs better.

B. End-to-End Delay

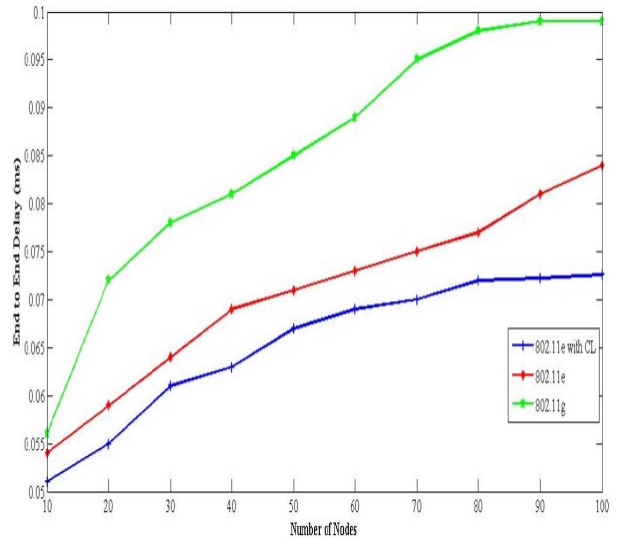

Figure 8 End-to-End Delay

Figure 8 shows the end-to-end delay for the evaluated scenarios. Again the use of proposed cross layer technique reduces end-to-end delay as compared to base technology.

C. Packet Delivery Ratio

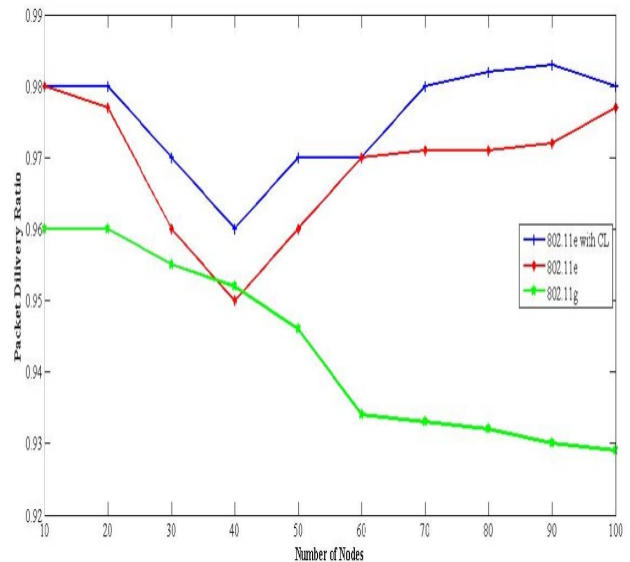

Figure 9 Packet Delivery Ratio

Figure 9 illustrates the packet delivery ratio for the evaluated scenarios. We observed the use of proposed cross layer technique causes considerable improvement in the PDR as compared to base technology.

IV. CONCLUSION

The proposed cross layer architecture for communication in MANET provides a stable route using SNR feedback, traffic classification on the basis of QoS without any hardware and provides flow control in between two links by using APRC packets. Calculation of SNR at MAC layer is a regular process of the network. We just forward this information to the network layer, network layer receives the SNR and determine the link condition. According to link condition, route re-establishment process is initiated and it provides a stable route during data transmission without any complex overhead.

The traffic classification at the MAC layer is a parameterized process. In this process the application layer transfers the classification parameter to the MAC layer without any intermediate layer. The MAC layer receives the regular data traffic, the traffic classifier classifies the traffic on the basis of receiving parameter and maintain the classified data packet queue for various data transmission packets. This is a comparison based process which takes minimum computational overhead.

The APRC is used to maintain the data flow in between sender and receiver, using the feedback mechanism of the MAC layer to the application layer.

The real time video transmission requires a jitter free delay in packets and the proposed architecture meets all the requirements without any aid of additional hardware and complex algorithms. Results show that the proposed strategy leads to performance improvement under several metrics, i.e. routing overhead, packet delivery ratio and end-to-end delay and hence a good quality video is received at the destination side.

REFERENCES

- [1] I. Moerman and P. Demester J. Hoebeke, "An Overview of Mobile Adhoc Networks: Applications and Challenges," in *Department of Information Technology*, Ghent, 2004, pp. 60-66.
- [2] C.K. Toh, *Adhoc Mobile Wireless Networks: Protocols and Systems*, 2nd ed. India: Pearson Education, 2001.
- [3] E.M. Royer and C.K. Toh, "A Review of Current Routing Protocols for Adhoc Mobile Wireless Networks," *IEEE Personal Communication Magazine*, vol. 21, no. 6, pp. 46-55, April 1999.
- [4] C.E. Perkins and P. Bhagwat, "Highly Dynamic Destination-Sequenced Distance Vector Routing (DSDV) for Mobile Computers," in *Proceedings of the Conference on Communication Architecture, Protocols and Applications*, New York, 1994, pp. 234-244.
- [5] C.E. Perkins and E.M. Royer, "Adhoc On-Demand Distance Vector Routing," in *Mobile Computing Systems and Applications*, New Orleans, 1999, pp. 90-100.
- [6] S. Celebi and M. Ganesan, "Wireless Medium Access Control Enhancement for Quality of Service (QoS)," in *IEEE International Conference on Wireless Networks*, Hongkong, 2001, pp. 1-5.
- [7] M. Conti and G. Masork Designelli et al., "Cross Layering in Mobile Adhoc Network Design," *Computer*, vol. 37, no. 2, pp. 48-51, February 2004.
- [8] V. Srivastav and M. Motwani, "Cross Layer Design: A Survey and the Road Ahead," *Communications Magazine*, vol. 43, no. 12, pp. 48-51, December 2005.
- [9] V.K. Goyal, "Multiple Description Coding: Compression Meets the Network," *IEEE Signal Processing Magazine*, vol. 18, no. 5, pp. 74-93, September 2001.
- [10] J. Apostolopoulos, "Reliable Video Communication over Lossy packet Networks Using Multiple state encoding and path Diversity," in *Proceedings of Visual communication and image Processing*, California, 2001, pp. 392-409.
- [11] S. Mao and S.Lin et al., "Video Transport over Adhoc Networks: Multistream Coding with Multipath Transport," *IEEE Journal Selected Areas Communication*, vol. 21, no. 10, pp. 1721-1737, December 2003.
- [12] M. Tesanovic, D. R. Bull and A. Doufexi, "Enhanced Error-Resilient Video Transport over MIMO Systems using Multiple Descriptions," in *IEEE Vehicular Technology Conference*, Montreal, 2006, pp. 1-5.
- [13] E.G. Larsson and P. Stoica et al., *Space time Block Coding for Wireless Communication*, 3rd ed. New York, USA: Cambridge University Press, 2003.
- [14] J. Kim and J.C. Hong, "Channel Adaptive Multiple Description Coding for Wireless Video Streaming," in *International Conference on Computer Communications and Networks*, Honolulu, 2007, pp. 474-478.
- [15] P. Timothy and P. Xiao-Hong, "Hybrid TCP/UDP Video Transport for H.264/AVC Content Delivery in Burst Loss Networks," in *IEEE International Conference on Multimedia and Expo*, Spain, 2011, pp. 1-5.
- [16] V.C. Frias and G.D. Delgado et al., "Multipath Routing with Layered Coded Video to Provide QoS for Video Streaming over MANET," in *IEEE International Conference on Networks*, Singapore, 2006, pp. 1-6.
- [17] K. Katsaggelos and Dalei Wu et al., "Application Centric Routing for Video Streaming over Multihop Wireless Networks," in *Sensor, Mesh and Adhoc Communications and Networks*, Rome, 2009, pp. 385-391.
- [18] Y. Andreopoulos and N. Mastronarde et al., "Cross Layer Optimized Video streaming over Wireless Multihop Mesh Networks," *IEEE Journal in Selected Areas in Communication*, vol. 24, no. 11, pp. 2104-2115, November 2006.
- [19] N. Gomathi and A. Govardhan et al., "A Cross Layer Design to Enhance Throughput for Multimedia Streaming over MANET," *International journal on Computer Science and Engineering*, vol. 3, no. 1, pp. 114-126, June 2011.
- [20] G. Delgado and V. Frias et al., "Vista-XL: A Cross Layer Design for Video Streaming over Adhoc Networks," in *International Symposium on Wireless Communication Systems*, Valencia, 2006, pp. 243-247.
- [21] Y. Jiazi and A. Adnane et al., "Multipath Optimized Link State Routing for Mobile Adhoc Networks," *Journal Adhoc Networks*, vol. 9, no. 1, pp. 28-47, January 2011.
- [22] J. Alcober and J.C. Cano et al., "Supporting Scalable Video Transmission in Manet through Distributed Admission Control Mechanism," in *18th Euromicro Conference on Parallel, Distributed and Network Based Processing*, Pisa, 2010, pp. 44-48.
- [23] M.A. Igartua and V.C. Frias, "Self Configured Multipath Routing Using Path Lifetime for Video Streaming Services over Adhoc Networks," *Journal Computer Communication*, vol. 33, no. 15, pp. 1879-1891, September 2010.
- [24] S. Kompella and S. Mao et al., "Cross Layer Optimized Multipath Routing for Video Communication in Wireless Networks," *IEEE Journal on Selected Areas in Communication*, vol. 25, no. 4, pp. 48-60, May 2007.